

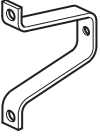

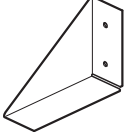
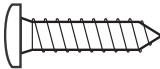

ADVANCED SHOWERS INTERNATIONAL LIMITED

20 Quadrum Park, Old Portsmouth Road, Guildford GU3 1LU Tel: 01483 532020 Fax: 01483 532080 Email: sales@advanced-showers.com

Optional legs & access panel fixing brackets

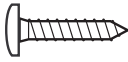
Components				
				
Steel Legs x 4*	Fixing Bracket x 2*	25mm Screw x 4*	Screw Cover Cap x 2*	19mm Screw x 2*

*For 1250 models an additional fifth steel leg, a fixing bracket, screw cover caps and screws are provided with the shower cabinet.

Assembly Instructions

Please note that the illustrations in these instructions relate to the 800W model.

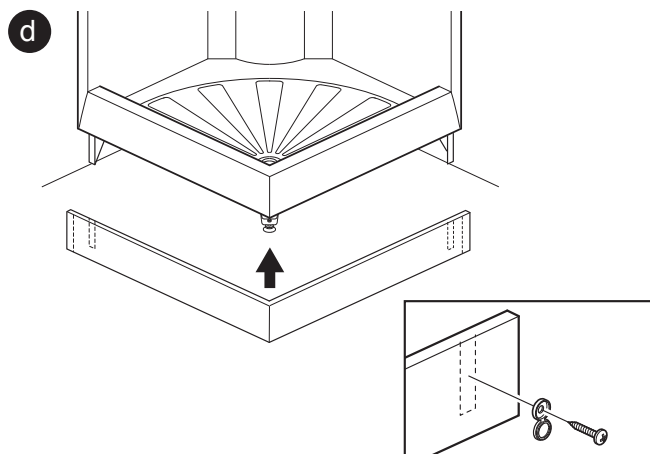
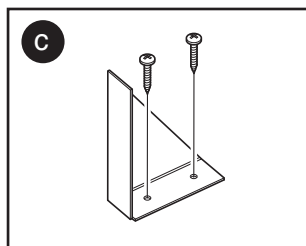
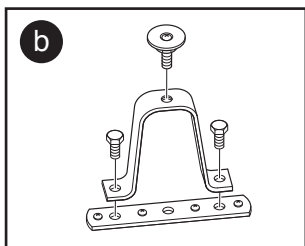
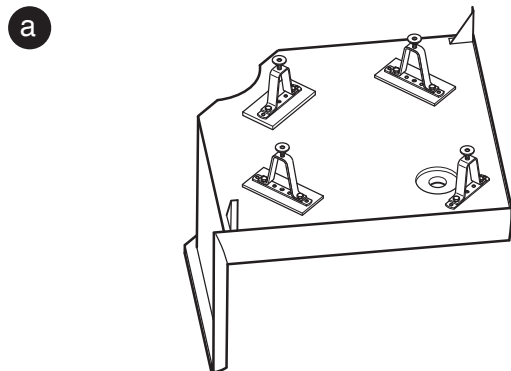

The optional legs are bolted to the underside of the shower cabinet to raise the cabinet off the floor. The adjustable feet are fixed onto the legs.

The access panel fixing brackets are screwed into the pilot holes in the baseboard to take the optional access panel once the shower has been installed. Once fixed, the access panel is designed to rest on the floor surface.

The optional legs and access panel fixing brackets are fitted before installation of the shower cabinet.

Turn the base section over onto its back (a) onto a clean surface. (Base shown after legs fitted).

Unscrew the adjustable feet and bolts (17mm spanner) from all of the leg fixing plates and keep for re-use.

Fix the leg brackets firmly to the fixing plates with the bolts and screw the adjustable feet into the bottom of each leg (b).

Fix the access panel brackets to the pre-drilled pilot holes in the baseboard where shown using the 25mm screws provided (c).

Carefully turn the base section back over onto its legs.

When the shower cabinet has been installed and tested slide the access panel into place under the shower cabinet. If necessary cut the access panel to length by trimming an equal amount from each end using a fine toothed saw (d).

Using a 3mm HSS drill bit, drill a pilot hole through the access panel into each fixing bracket. Place a screw cover cap over each self tapping 19mm screw and fix the access panel to both brackets with the 2 screws (d detail).